

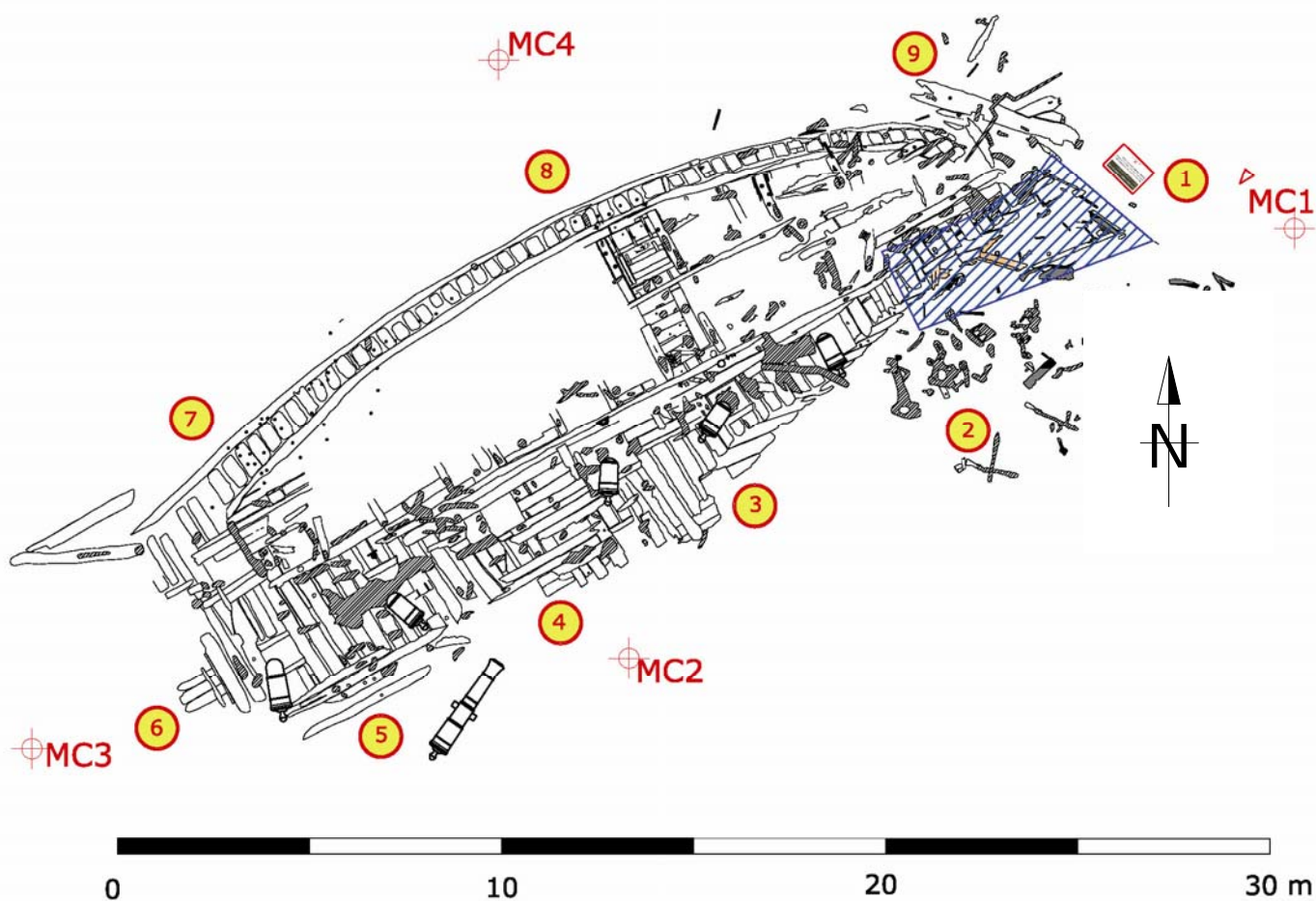

ENGLISH HERITAGE

HMS Colossus Dive Trail



HMS Colossus Dive Trail

Read this page before the dive

HMS Colossus was a 74 gun warship built in 1787 at Gravesend and wrecked in 1798. These 74 gun ships were one of the most successful types of the period. They were about 51m (170 feet) in length and had a crew of over 600. During her relatively short working life (eleven years) *Colossus* saw action at Toulon, Groix, Cape St Vincent and Cadiz. She also took part in the capture of two enemy ships *Le Vanneau* and *Vrai Patriot* in 1793

In December 1798 *Colossus* was on her way home to England with a remarkable cargo including eight crates of Greek antiquities, wounded sailors from Nelson's victory at the battle of the Nile and the body of a dead admiral. What she did not have on board was one of her spare bower anchors, which had been given to Nelson's ship *Vanguard* in Naples. This would prove to be disastrous. She was sheltering from a gale in St Mary's Roads when the anchor cable parted and she was driven aground to the south of Samson. All but one member of the crew were taken off safely before *Colossus* turned onto her beam ends and proceeded to break up.

The wreck lies on its port side and what you will see are the inside timbers of the ship's hull. There are nine dive stations at points of interest around the wreck. Follow the shot line to the seabed, and the site is 20m south west of the shot line – there is a lead line you can follow from the shot to seabed station 1. Each seabed station has an arrow pointing to the next station.

More information about the work on the wreck of *Colossus* is available at www.cismas.org.uk . If you would like to see photographs or accounts of your visit on the web site please email to: darkwright@talktalk.net

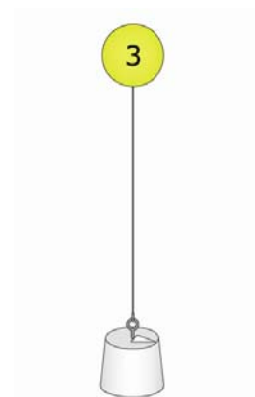

Station

1

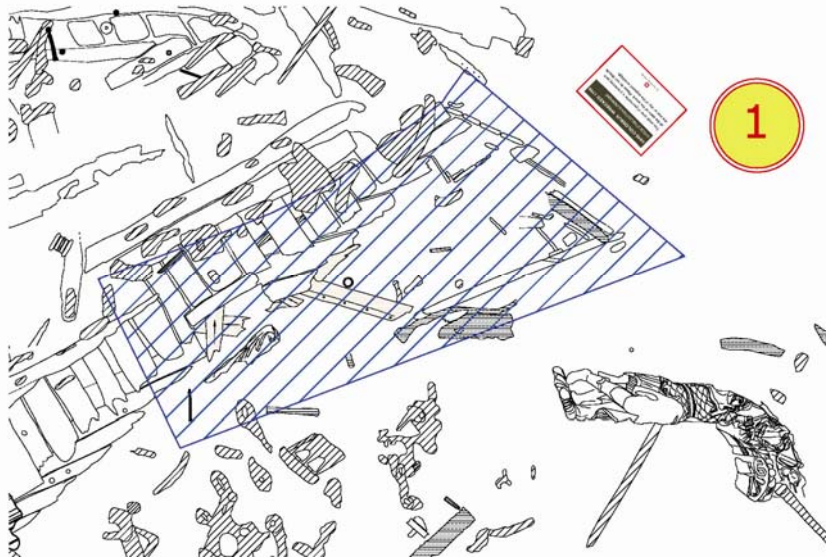

You are at the stern of the wreck. The seabed sign is situated where the stern windows of the Captain's cabin would have been. The white Terram mat in front of you is protecting an area of timber from further decay. This forms part of a long term study into ways of protecting the remains of this wreck. Notice how the Terram and sand bags are already covered in seaweed and sediment.

Next Station

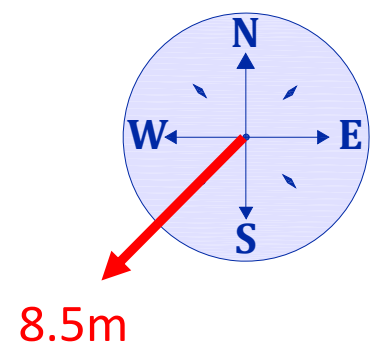

Station

2

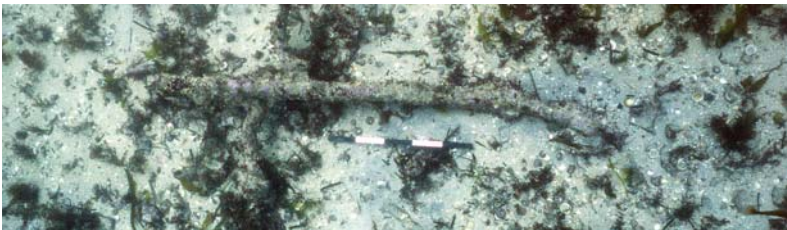
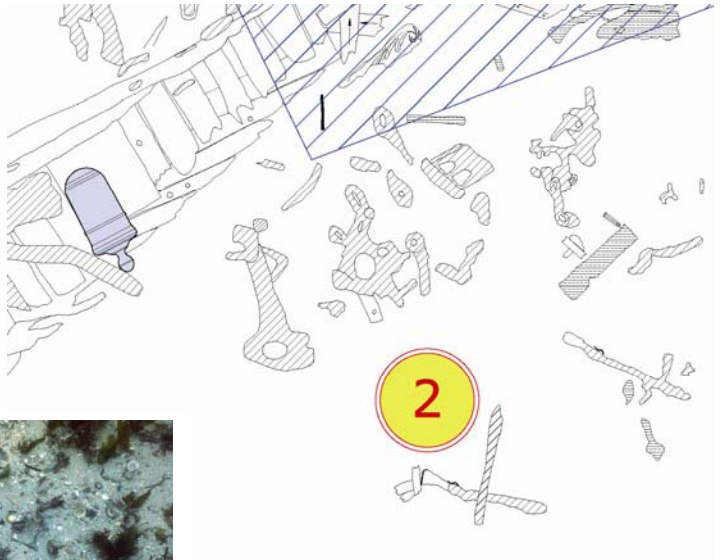

Here you can see the remains of several muskets. These were used by the 120 marines on board *Colossus*, as well as by the ordinary seamen. These are sea service muskets, similar to the well known 'Brown Bess' of the British Army, but simpler and slightly shorter than the standard land musket. They were smooth-bore flint-lock weapons and fired a lead ball of 0.75 inch diameter. The accuracy of this type of weapon was low; the effective range would have been well under 100m. The barrel is made from steel, the stock is wood and the trigger guard and butt plate are copper alloy.

Station

2

This is what the now corroded muskets would have looked like. The musket was fired using black powder (gun powder), which was ignited by sparks generated by a flint striking a steel plate.



To the north of the muskets are a number of large iron objects. These are the remains of the mizzen chains, the iron fastenings which held the shrouds (supporting ropes) from the mizzen mast to the outside of the ship's hull.

Next Station

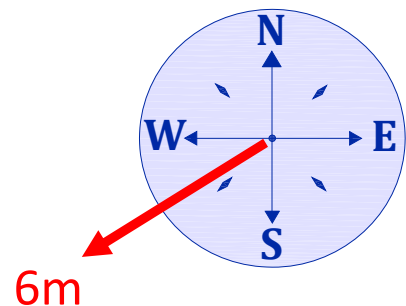

Station

3

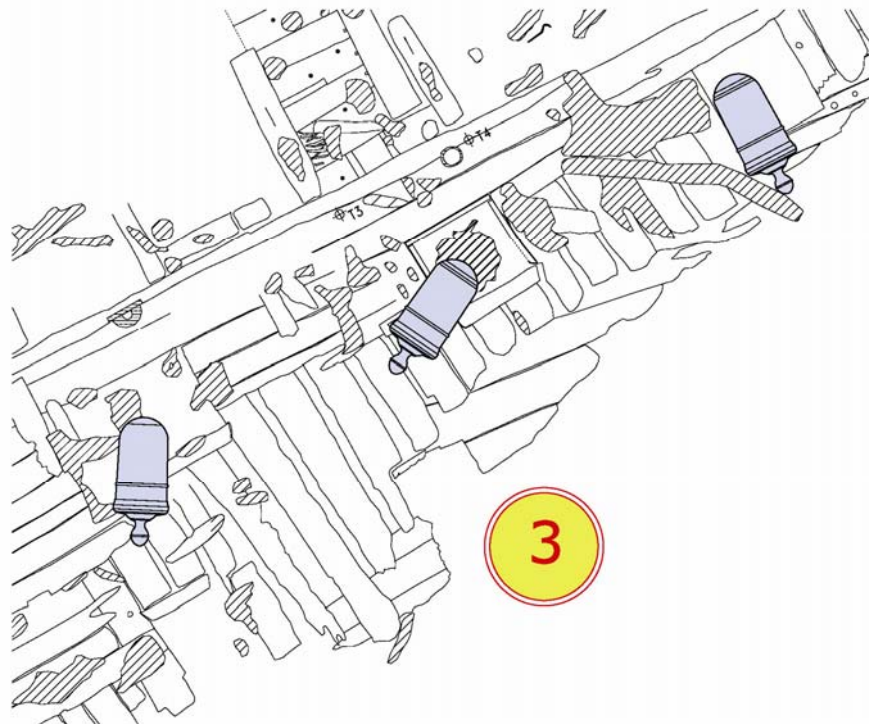

Turn to face north. In front of you now is one of the five eighteen-pound iron guns standing upright on the seabed, their muzzles buried in the sand. If you look carefully you will see that the guns are still within their gun ports. Immediately in front of you there is timber exposed on the seabed. This is the inside face of the ship. You will also see an empty gun port very close to station 3. This is one of the quarter deck gun ports, where smaller nine-pound guns would have been.

Station

3

Colossus carried 74 guns on three different levels. These were all smooth-bore cast iron guns designed to fire a variety of projectiles (grape, case, bar, chain and round shot). The guns were classified according to the weight of round shot they fired. The lower gun deck had 28 thirty-two pound guns; the upper deck had 28 eighteen-pound guns while the quarterdeck and forecastle held the remaining 18 nine-pound guns. The guns visible on site are eighteen-pound guns of the Armstrong type, while the lower deck guns were the newer Blomefield design.



Next Station

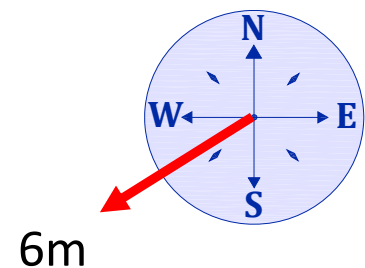

Station

4

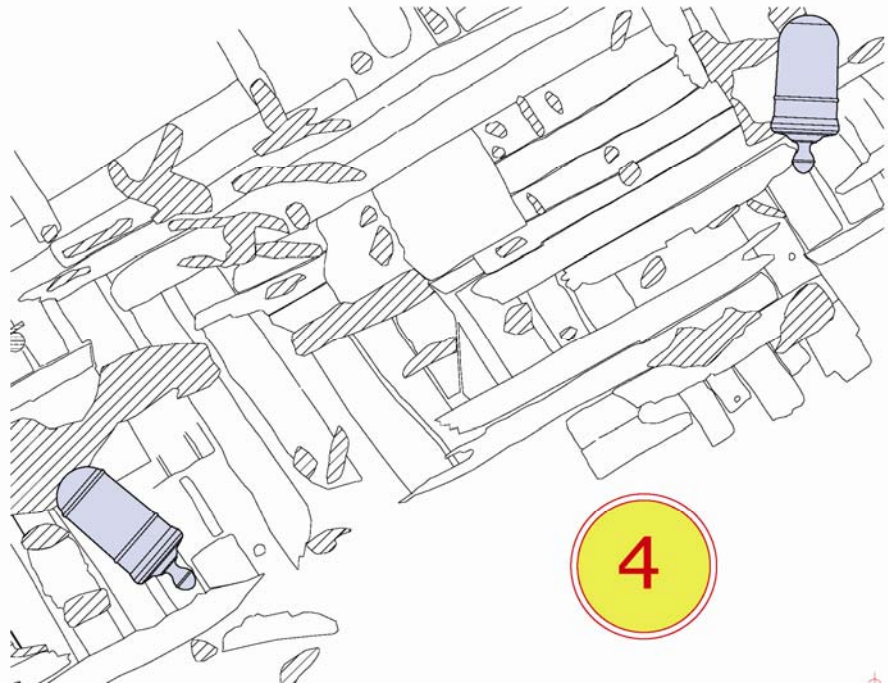

About two metres to the north of station 4 you will find an empty gun port. This gives a clear idea of what the gun ports looked like. Remember you are looking at the inside of the gun port. Notice the corroded iron ring bolts at the side of the gun port, which would have been used to secure the gun carriage to the side of the ship. If you look closely at the timber on the seabed, you will see the tunnels in the timber created by the wood-boring organisms which are attacking the hull timbers.

Station

4

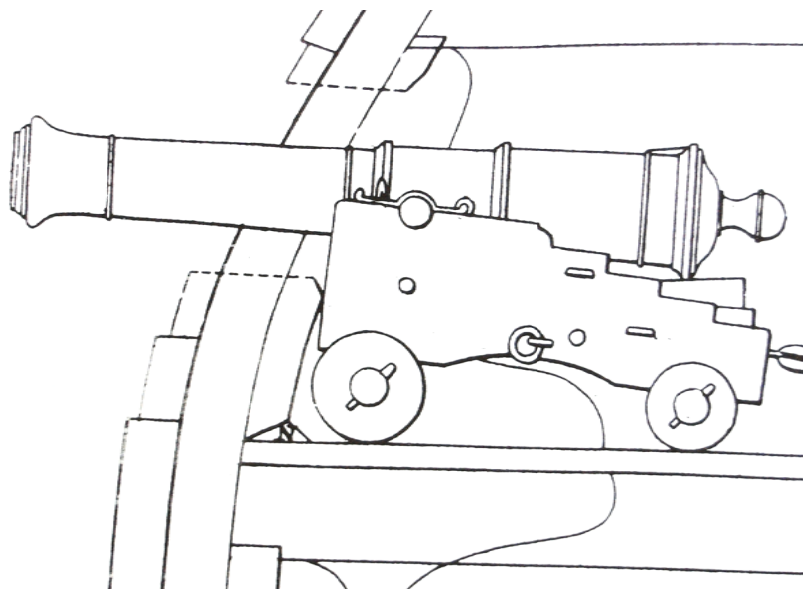

Three metres to the west of station 4 you will find another of the upstanding eighteen-pound guns. If you look carefully you will see a number of iron bolts attached to the barrel of the gun. These are the iron fastenings which held the wooden gun carriage together. The timber of the carriage has now decayed, leaving only the iron fastenings.

Next Station

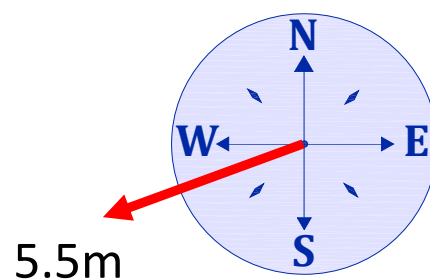

Station

5

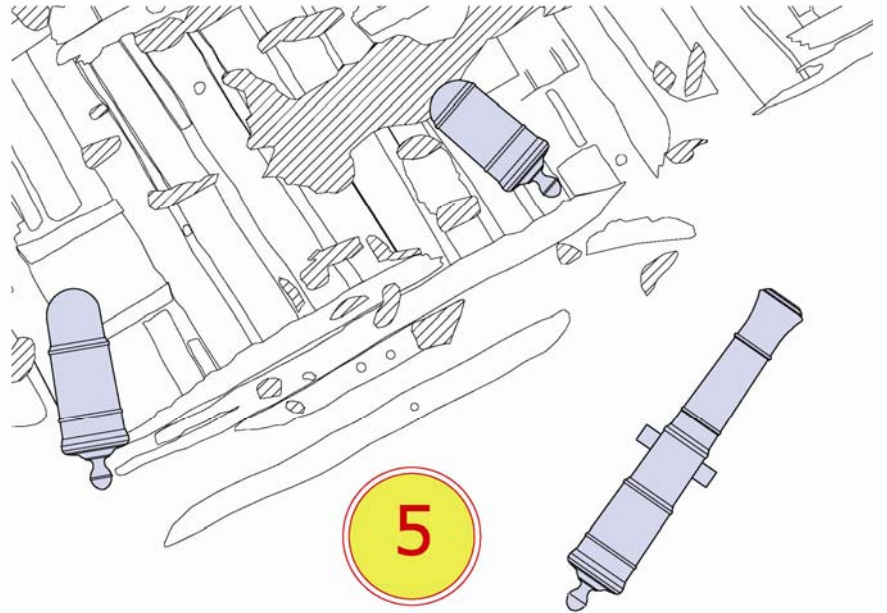

At station 5 you can see one of the eighteen-pound guns lying flat on the seabed. This gun is probably the one which was originally sited at the empty gun port you saw at station 4. Here you can see just how large these guns are. They are 2.75m (9 ft) long and weigh 2 tonnes each. The lower deck guns (thirtytwo-pound) were even larger.

Next Station

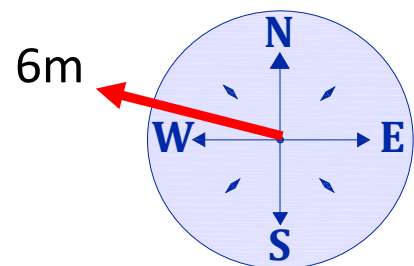

Station

6

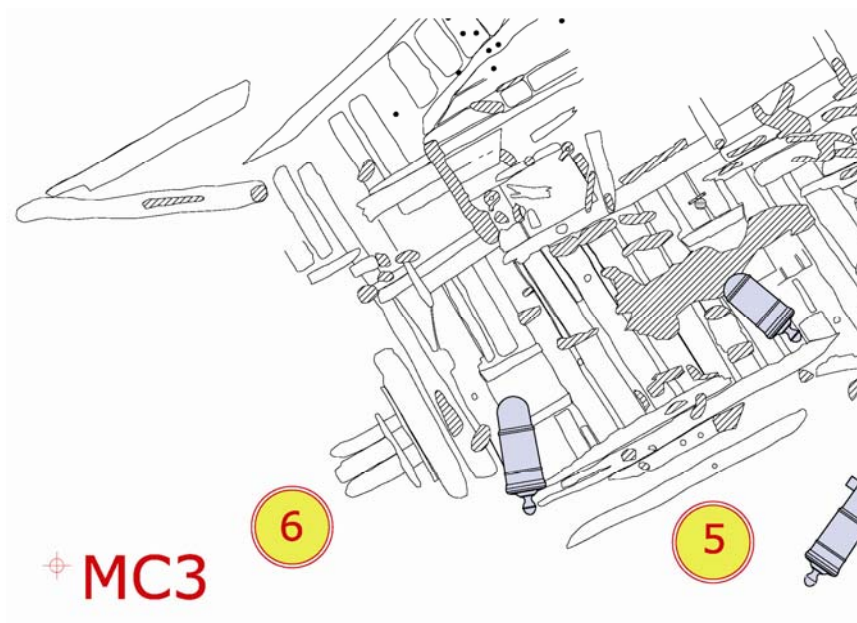

You are now at the point where the ship broke in half – roughly where the mainmast was. The bow section of the wreck is over 300m to the west; this was excavated in the 1970's by Roland Morris. He recovered thousands of pieces of Greek pottery (now in the British Museum) which were part of the cargo of *Colossus* when she sank.

Next Station

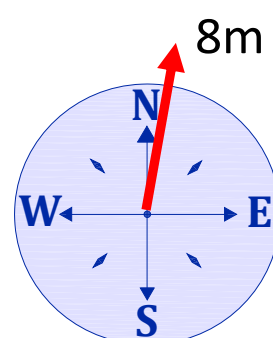

Station

7

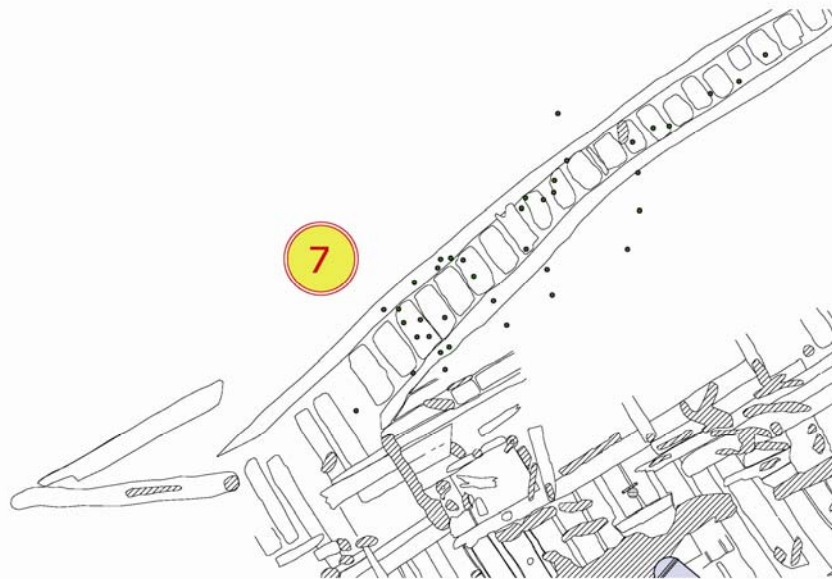

You can now see a number of copper spikes standing upright on the seabed. These are the remains of the copper bolts used to fasten the timbers of the hull. Before 1780 ships were fastened using iron bolts. After the introduction of copper sheathing below the waterline it was soon discovered that the iron bolts corroded rapidly. The solution to this problem was to use copper fastenings below the waterline. The sharp points seen on these copper bolts are caused by erosion of the exposed bolts on the seabed. Take care to avoid the sharp points!

Station

7



The timbers you see here are the partly buried hull timbers. These consist of the inner planking, frames and outer planking. You are at the level of the orlop deck, where cables and sails were stored, below the water line of the vessel.

Next Station

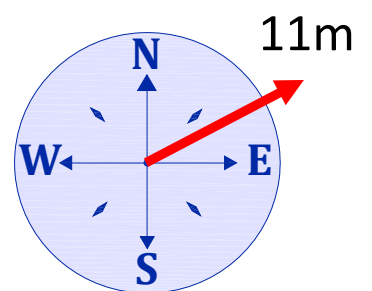

Station

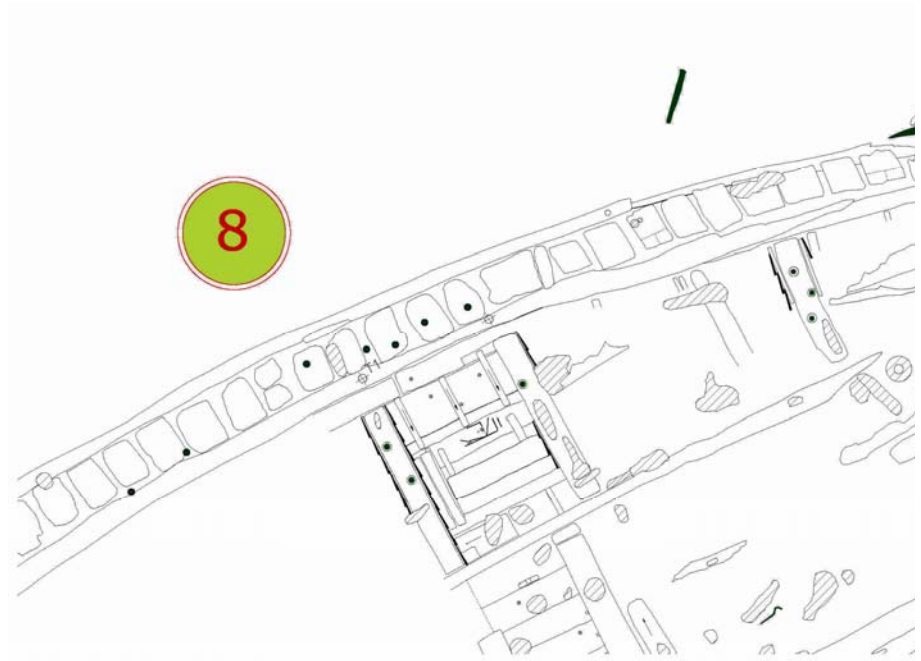

Turn so that you are facing south. In front of you are the timbers of the hull. You should also be able to see several copper fastening bolts similar to those you saw at the last station. If you look carefully at the outside of the hull (outer planking) you should be able to see some of the copper sheathing which covered the hull below the water line.

Station



The photograph here shows you roughly what the hull timbers look like at this point (looking east). On the left is the outer hull planking. In the middle, the large square timbers are the frames of the ship. On the right hand side is the inner planking. If you look carefully you should be able to see the joins in the planking. Again you will notice how the timbers are being attacked by wood boring organisms – sometimes called gribble.

Next Station

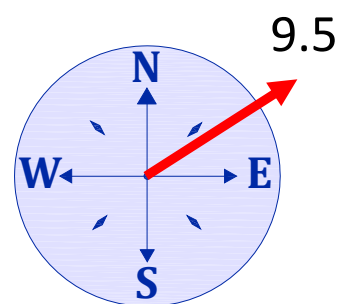

Station

9

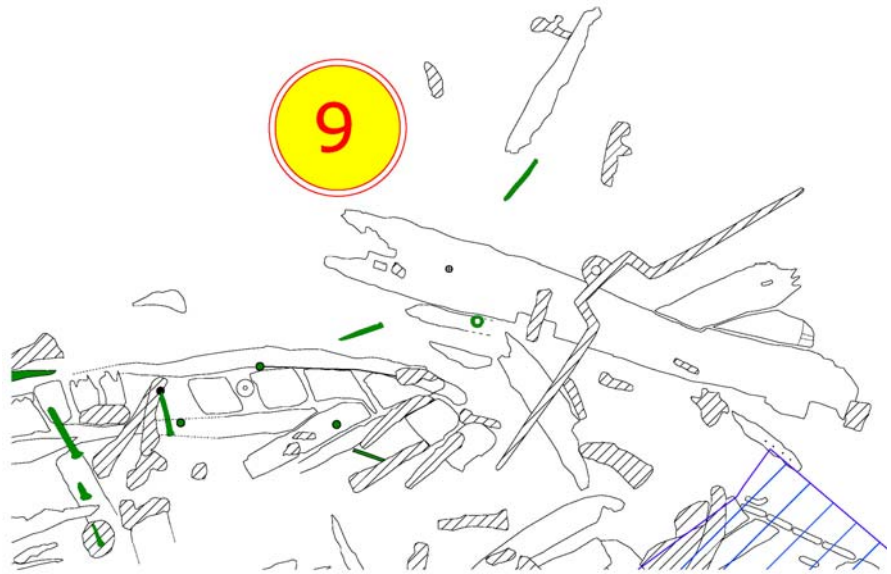

Here you can see part of the stern post of the ship. The large iron object on top of the timber is one of the rudder gudgeons, an iron strap used to attach the rudder to the hull (the gudgeons attach to the hull and the pintols attach to the rudder). The hole in the centre of the gudgeon is where the rudder pivoted on the pintol pin. Colossus lost her rudder when she first grounded some distance to the west of where you are now.

Station

9

This photograph of the stern of a model of a similar ship shows the position of the rudder gudgeon (arrowed).



Station 9 is the final station on our tour of the wreck. Follow the compass pointer to arrive back at station 1 and the seabed sign – where you started this tour.

Station One

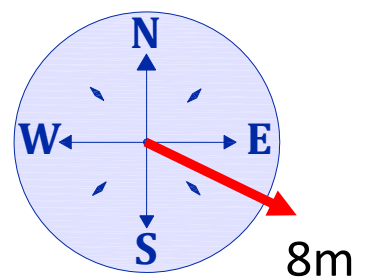

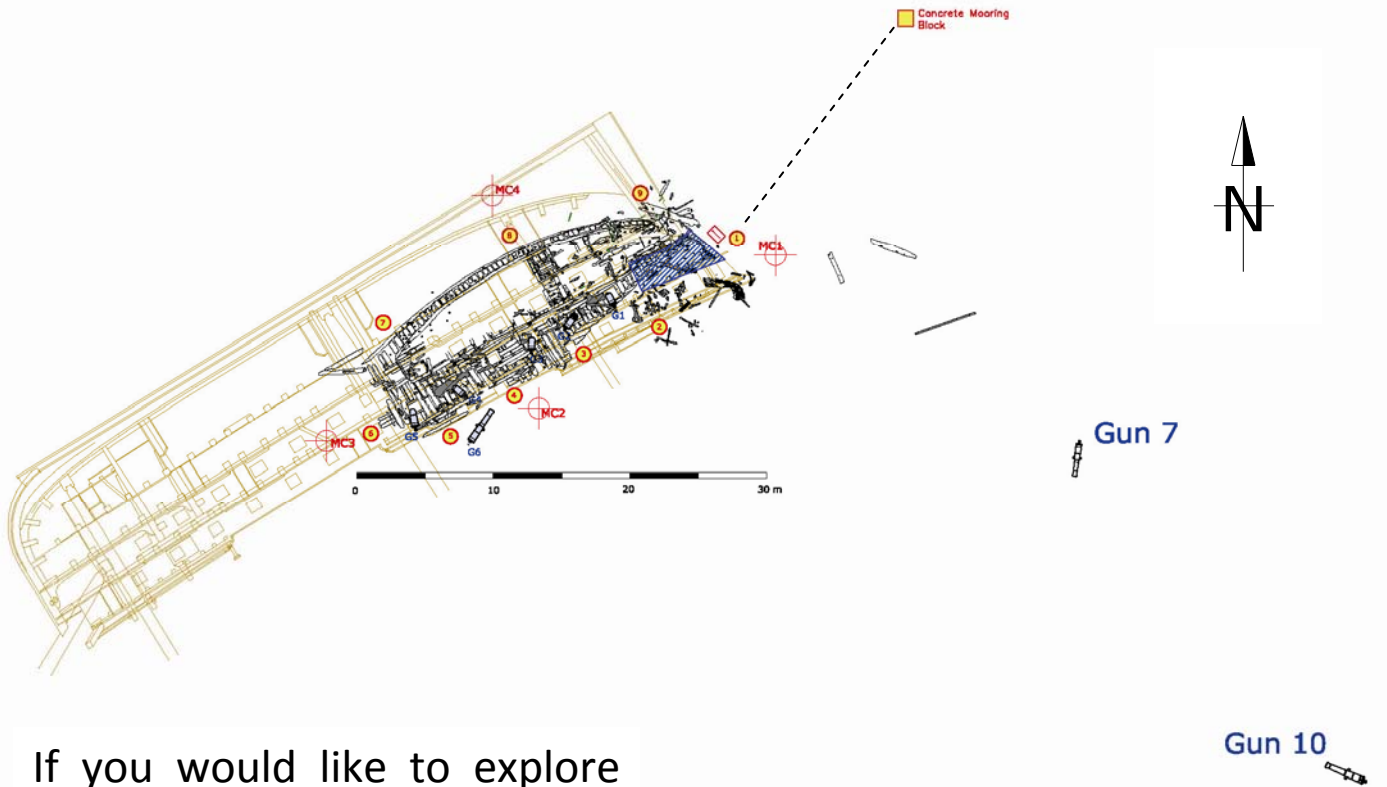

If you would like to explore further you may wish to visit some of the outlying guns from Colossus.

Gun 8 

Gun 7 is a nine-pound gun with parts of the gun carriage still attached. It lies 29m from station 1 on bearing 120°. Gun 10 is one of the Blomefield thirtytwo-pound guns from the main gun deck. It lies 53m from station 1 on bearing 130°.